

Crash rail – rounded ends – for concreting

As manufacturer we can offer you the following:

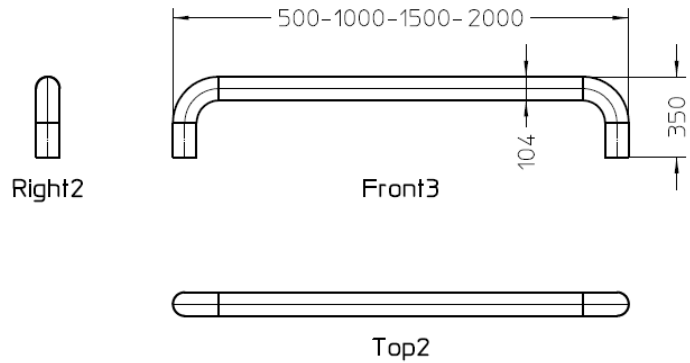

<ul style="list-style-type: none"> • Crash protection bar – rounded ends • For concreting • Stainless steel 304/316 • polished • Total height: 350 mm • Length: 500–1000–1500-2000 mm • Tube : Ø 104x2 mm • Seamless finishing • Filled with concrete 	Code					weight
	SB-AU-BT-104x2-350x 500 x350- rvs 304 -beton					21 kg
	SB-AU-BT-104x2-350x 500 x350- rvs 316 -beton					21 kg
	SB-AU-BT-104x2-350x 1000 x350- rvs 304 -beton					31 kg
	SB-AU-BT-104x2-350x 1000 x350- rvs 316 -beton					31 kg
	SB-AU-BT-104x2-350x 1500 x350- rvs 304 -beton					46 kg
	SB-AU-BT-104x2-350x 1500 x350- rvs 316 -beton					46 kg
SB-AU-BT-104x2-350x 2000 x350- rvs 304 -beton					58 kg	
SB-AU-BT-104x2-350x 2000 x350- rvs 316 -beton					58 kg	

These are the most ordered dimensions. Other dimensions are also possible.

For orders and price requests you can email us on: info@axra.be

