

Crash rail – straight ends – for concreting

As manufacturer we can offer you the following :

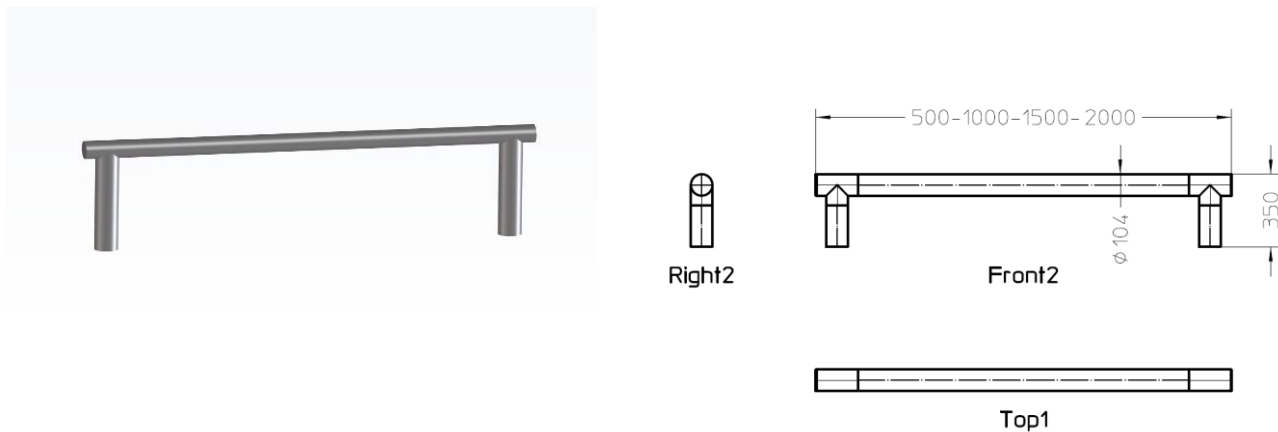

<ul style="list-style-type: none"> • Crash protection bar – straight ends • For concreting • Stainless steel 304/316 • polished • Total height: 350 mm • Length: 500–1000–1500-2000 mm • tube: \varnothing 104x2 mm • seamless finishing • filled with concrete 	Code				weight
	SB-RU-BT-104x2-350x 500 x350- rvs 304 -beton				21 kg
	SB-RU-BT-104x2-350x 500 x350- rvs 316 -beton				21 kg
	SB-RU-BT-104x2-350x 1000 x350- rvs 304 -beton				31 kg
	SB-RU-BT-104x2-350x 1000 x350- rvs 316 -beton				31 kg
	SB-RU-BT-104x2-350x 1500 x350- rvs 304 -beton				46 kg
	SB-RU-BT-104x2-350x 1500 x350- rvs 316 -beton				46 kg
	SB-RU-BT-104x2-350x 2000 x350- rvs 304 -beton				58 kg
	SB-RU-BT-104x2-350x 2000 x350- rvs 316 -beton				58 kg

These are the most ordered dimensions. Other dimensions are also possible.

For orders and price request you can email us on: info@axra.be

